

# Creston

## designer planter

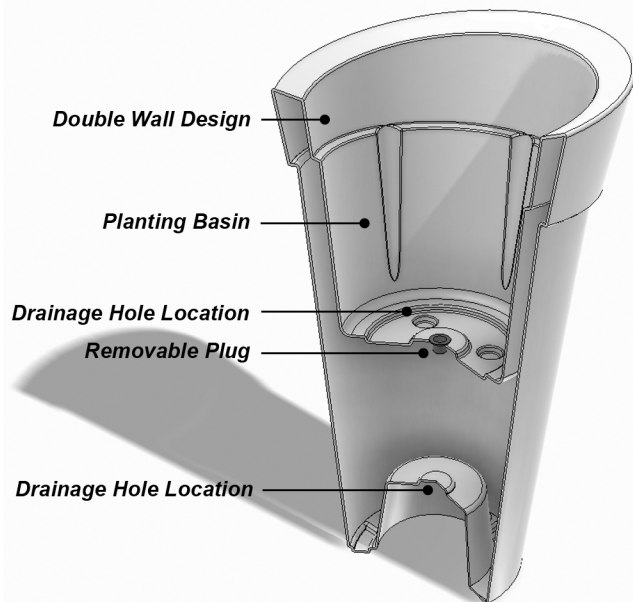

Model # 5881  
Polyresin Planter  
Indoor/Outdoor Use  
UV Protected  
Shock Resistant



### GENERAL INFORMATION:

- Molded from durable, all-weather polyethylene
- Drill drainage holes when using planters outdoors
- For increased stability we recommend filling in the inner cavity with sand or gravel
- Rinse clean with a garden hose; for a deeper clean, use a power washer

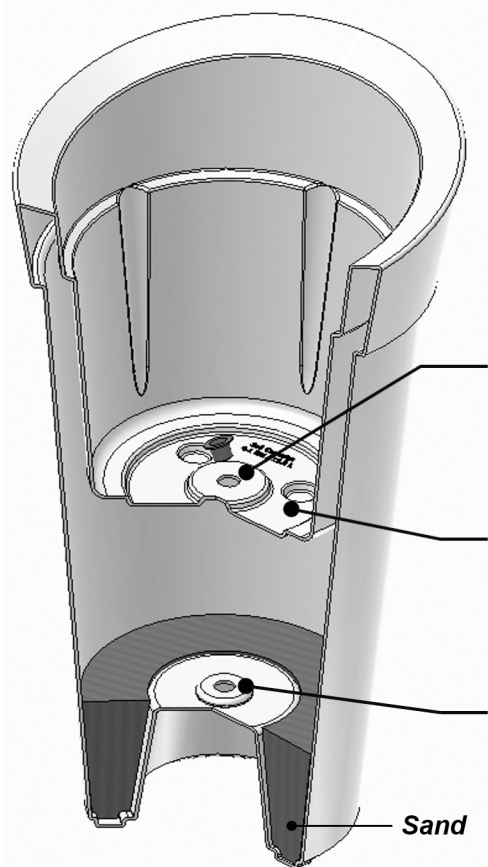

### INSTALLATION TIPS:

To increase stability, remove the rubber plug and use a funnel to fill the inner cavity with sand. Alternatives include pea gravel or crushed gravel. A slightly larger hole may need to be drilled if you choose this option.

For outdoor use drill 1.3 cm (1/2 in) drainage holes in the marked locations. There are 3 recessed areas in the bottom of the planter basin

For outdoor use be sure to drill a 1.3 cm (1/2 in) drainage hole in the bottom of the planter as well.



**MAYNE**  
Outdoor Products of Distinction  
[www.gomayne.com](http://www.gomayne.com)

For customer service inquiries email [customerservice@gomayne.com](mailto:customerservice@gomayne.com) or call toll free at 866-363-8834 (available Monday through Friday, 8am-5pm EST).

# Creston

## 28in Tall Planter

Colour Options: Black  
Soil Capacity: 4.1 gallons (15.5 Liters)  
Inside Dimensions: 12.6in Dia. x 11.5in Depth  
Wall Thickness: 0.12 inches  
Part Weight: 6.5 lbs  
Material: Polyethylene  
Note: Double Wall Design

